



US 20180110662A1

(19) **United States**

(12) **Patent Application Publication**
Doak

(10) **Pub. No.: US 2018/0110662 A1**

(43) **Pub. Date: Apr. 26, 2018**

(54) **MULTI-PURPOSE LITTER CLAMP AND ATTACHMENTS**

F16M 13/02 (2006.01)

F16B 2/12 (2006.01)

(71) Applicant: **Morzine Medical LLC**, Atlanta, GA (US)

(52) **U.S. Cl.**

CPC *A61G 1/04* (2013.01); *F16B 2/12* (2013.01); *F16M 13/022* (2013.01); *A61G 1/052* (2013.01)

(72) Inventor: **John H. Doak**, Baltimore, MD (US)

(73) Assignee: **Morzine Medical LLC**, Atlanta, GA (US)

(57)

ABSTRACT

(21) Appl. No.: **15/789,294**

(22) Filed: **Oct. 20, 2017**

Related U.S. Application Data

(60) Provisional application No. 62/410,467, filed on Oct. 20, 2016.

Publication Classification

(51) **Int. Cl.**

A61G 1/04 (2006.01)

A61G 1/052 (2006.01)

A multi-purpose litter clamp comprises a clamp that preferably spans below the litter connecting to opposing longitudinal litter poles on opposite sides of the litter. The clamp can attach rigidly and securely to both sides of the litter. In many embodiments, all but a few inches of the litter's longitudinal poles are covered with a nylon fabric that make up the 'bed' of the litter. A plurality of clamp accessories can facilitate rapid and effective attachment and/or removal of medical equipment connected to a patient directly to the litter on which the patient lies, either during transport and/or while in a field hospital.

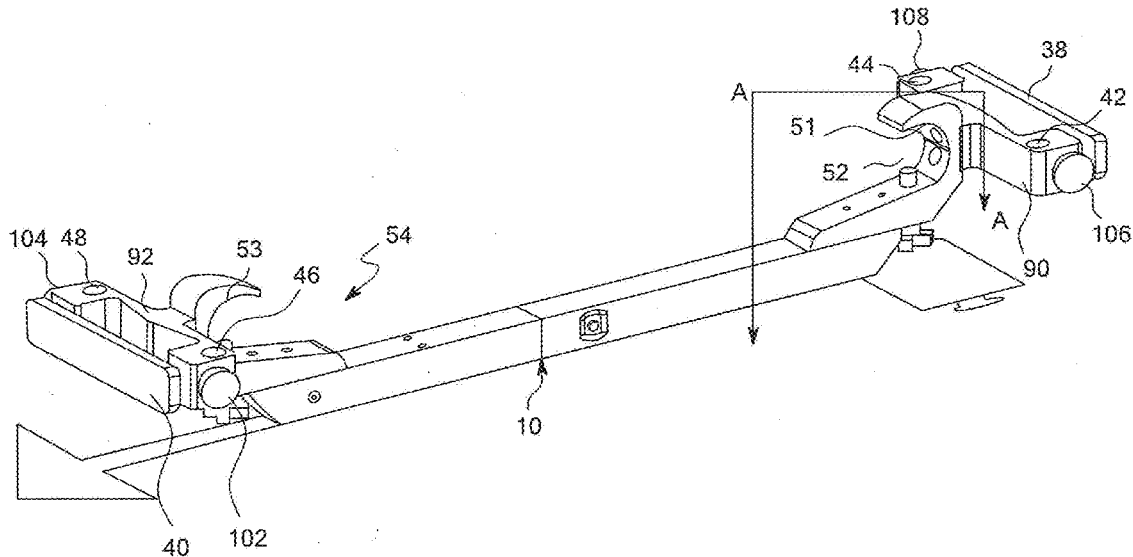

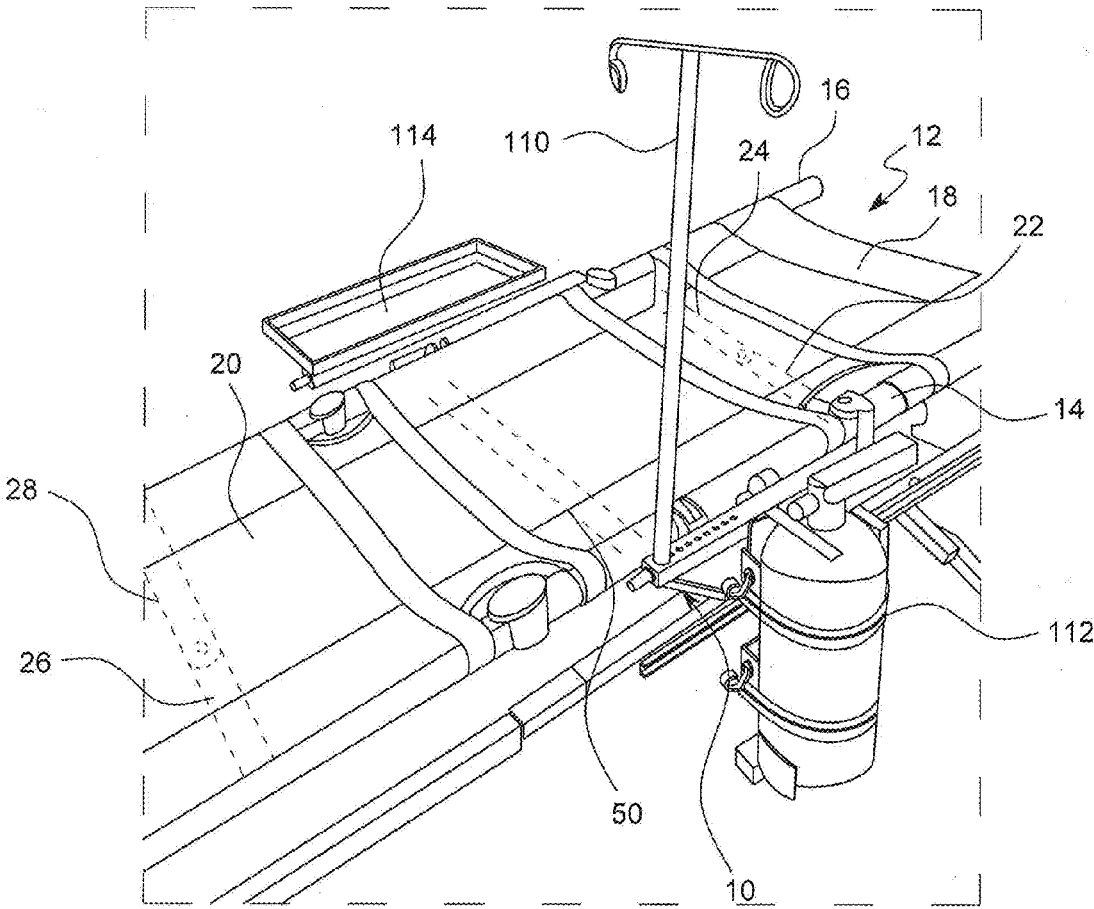

FIG. 1

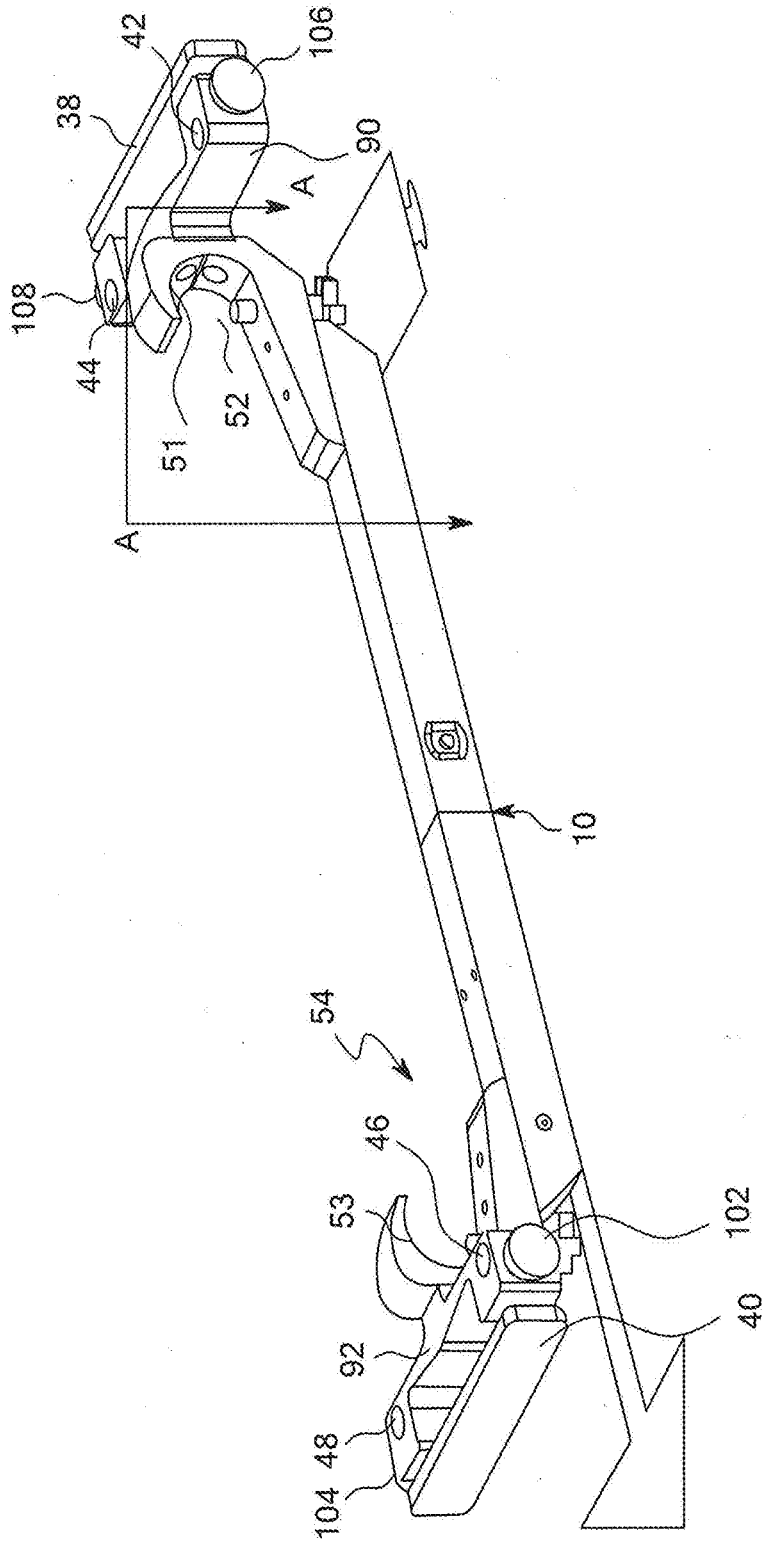

FIG. 2

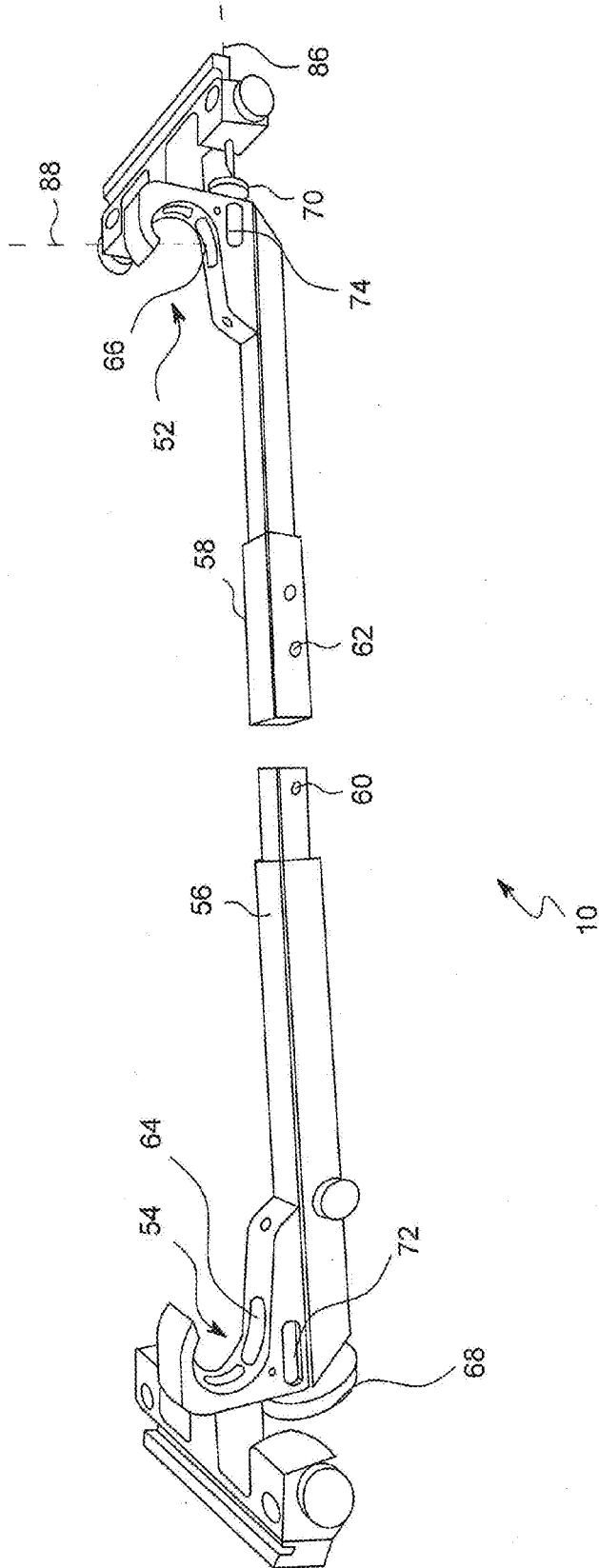

FIG. 3

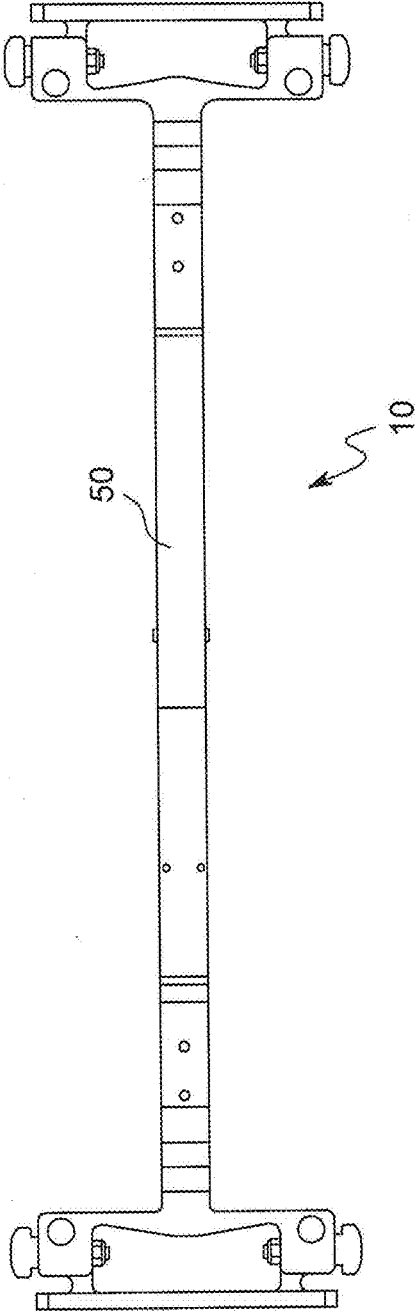

FIG. 4

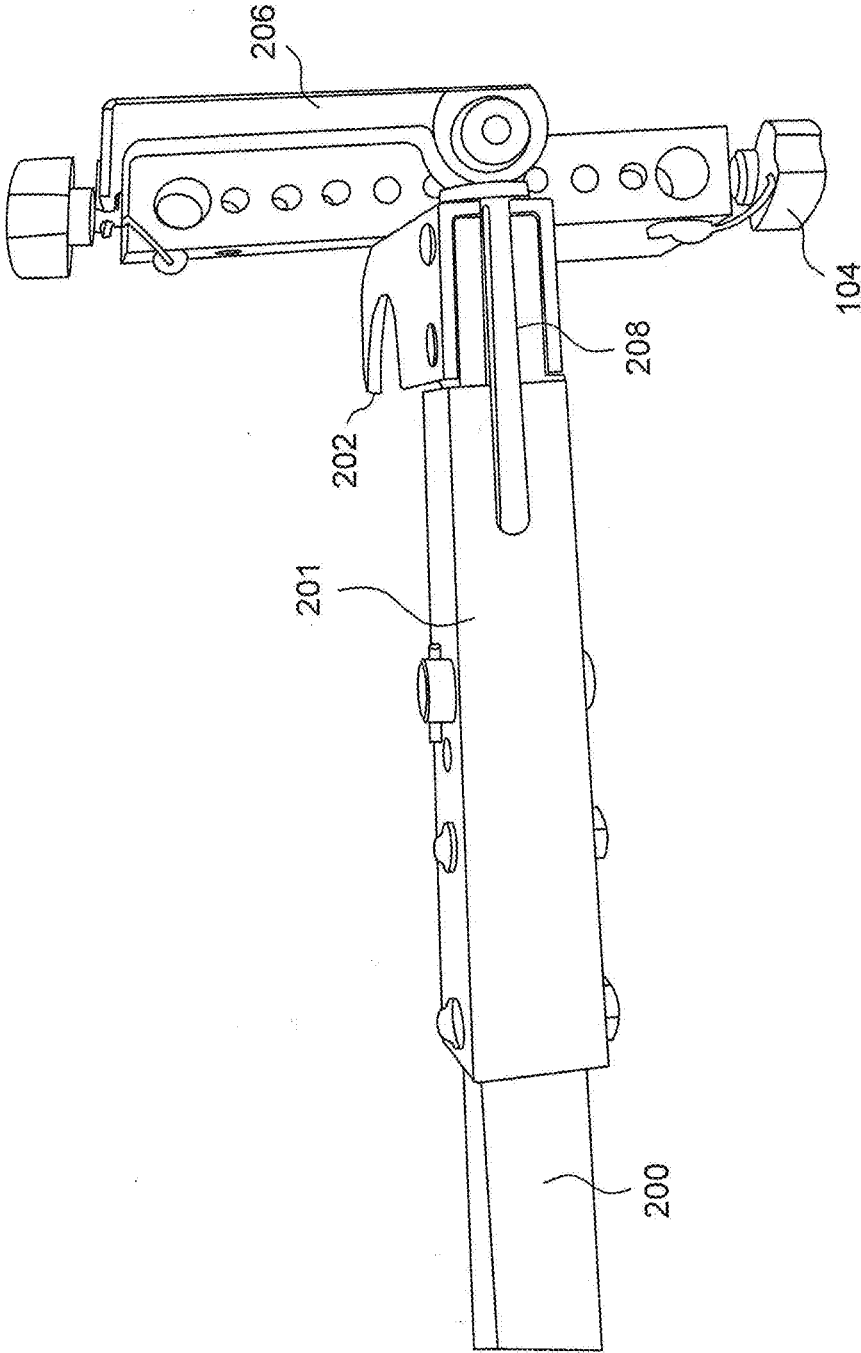

FIG. 5

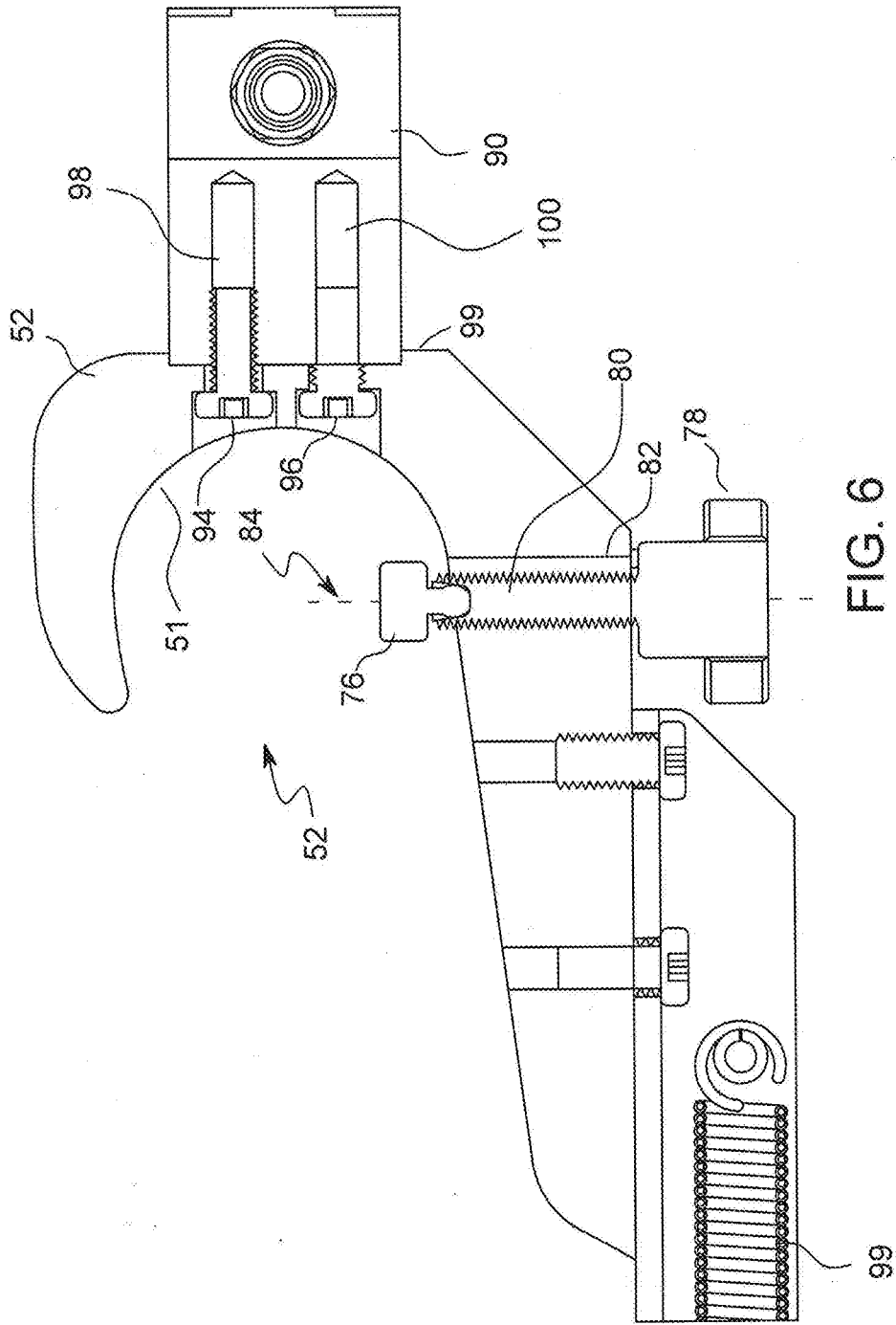

FIG. 6

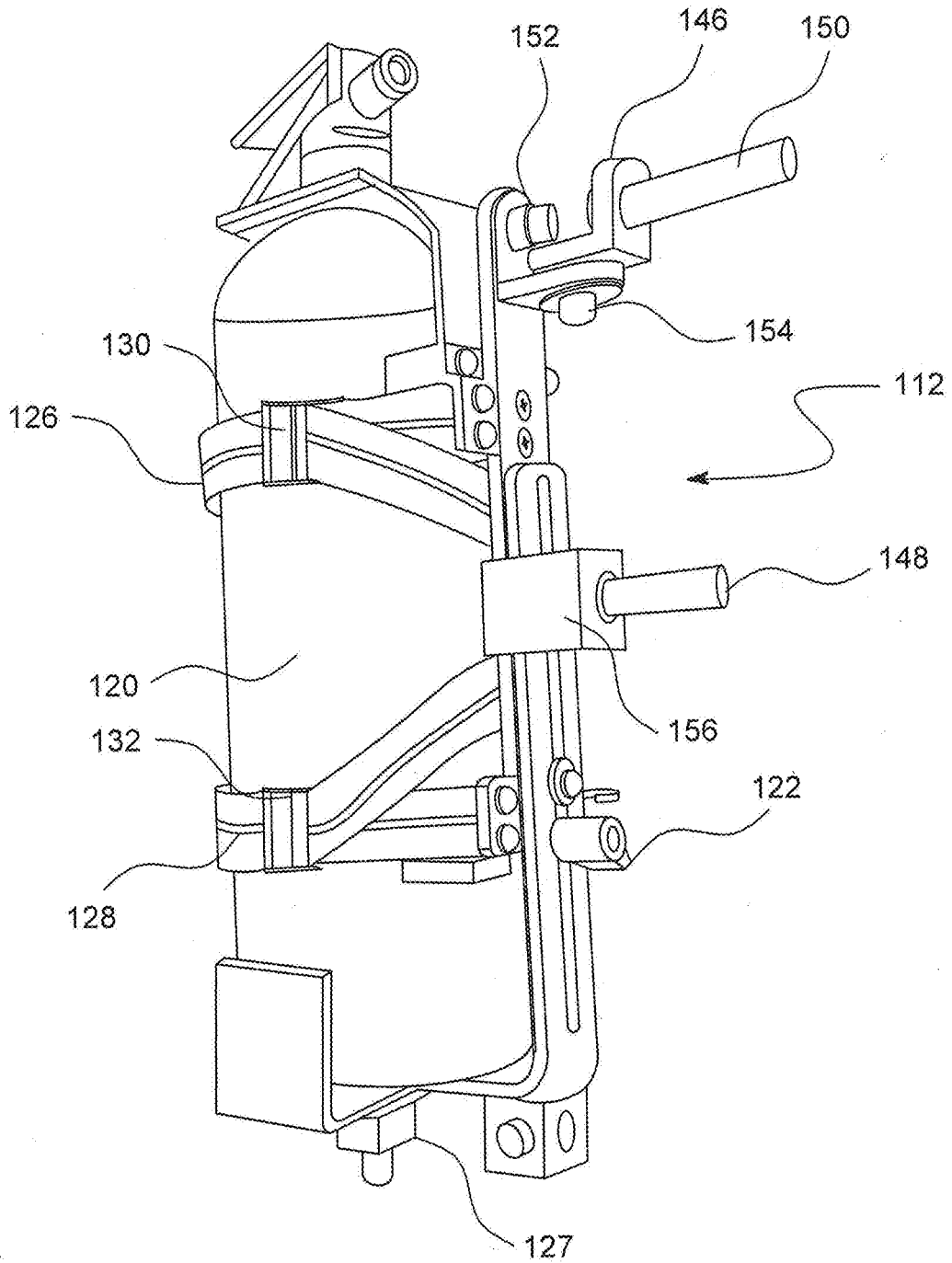

FIG. 7

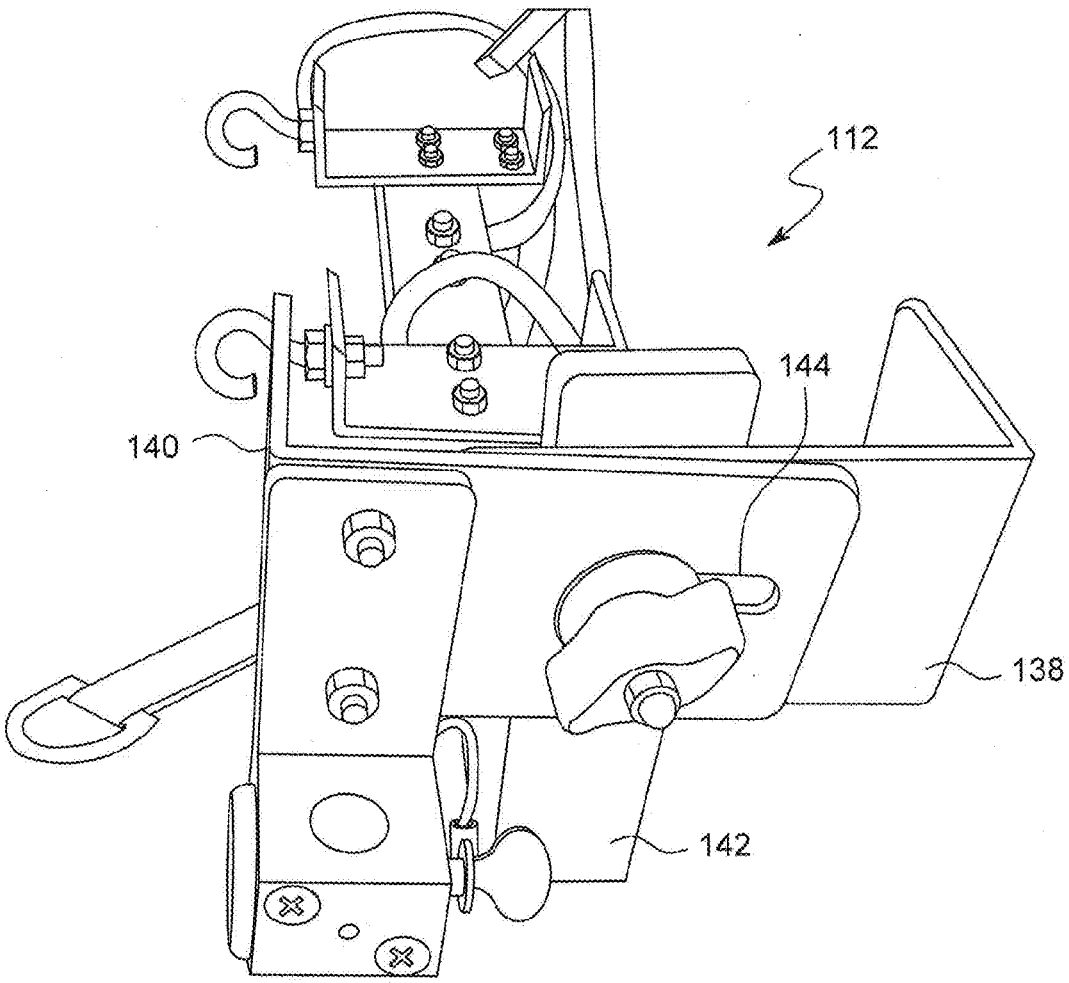

FIG. 8

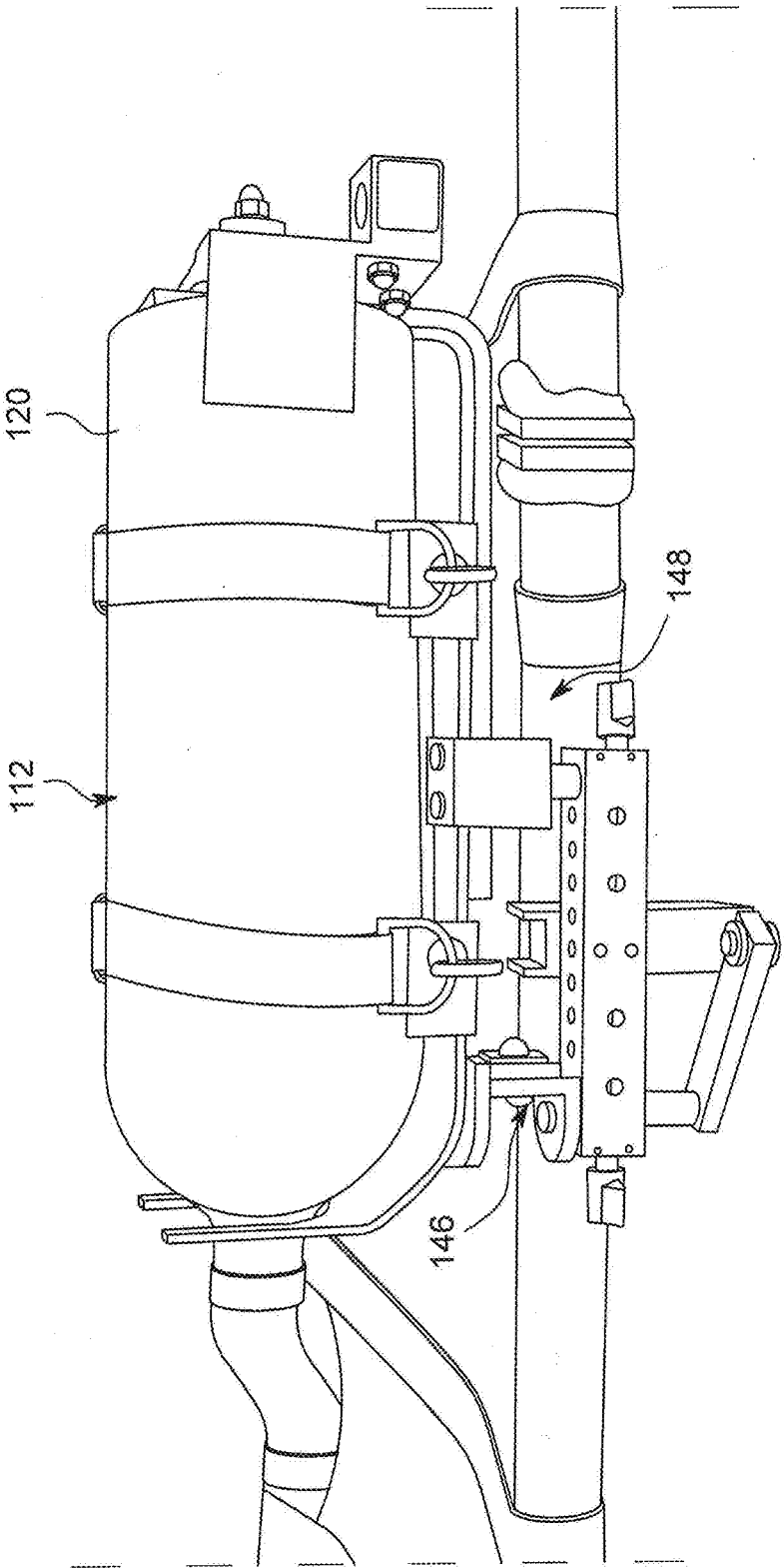

FIG. 9

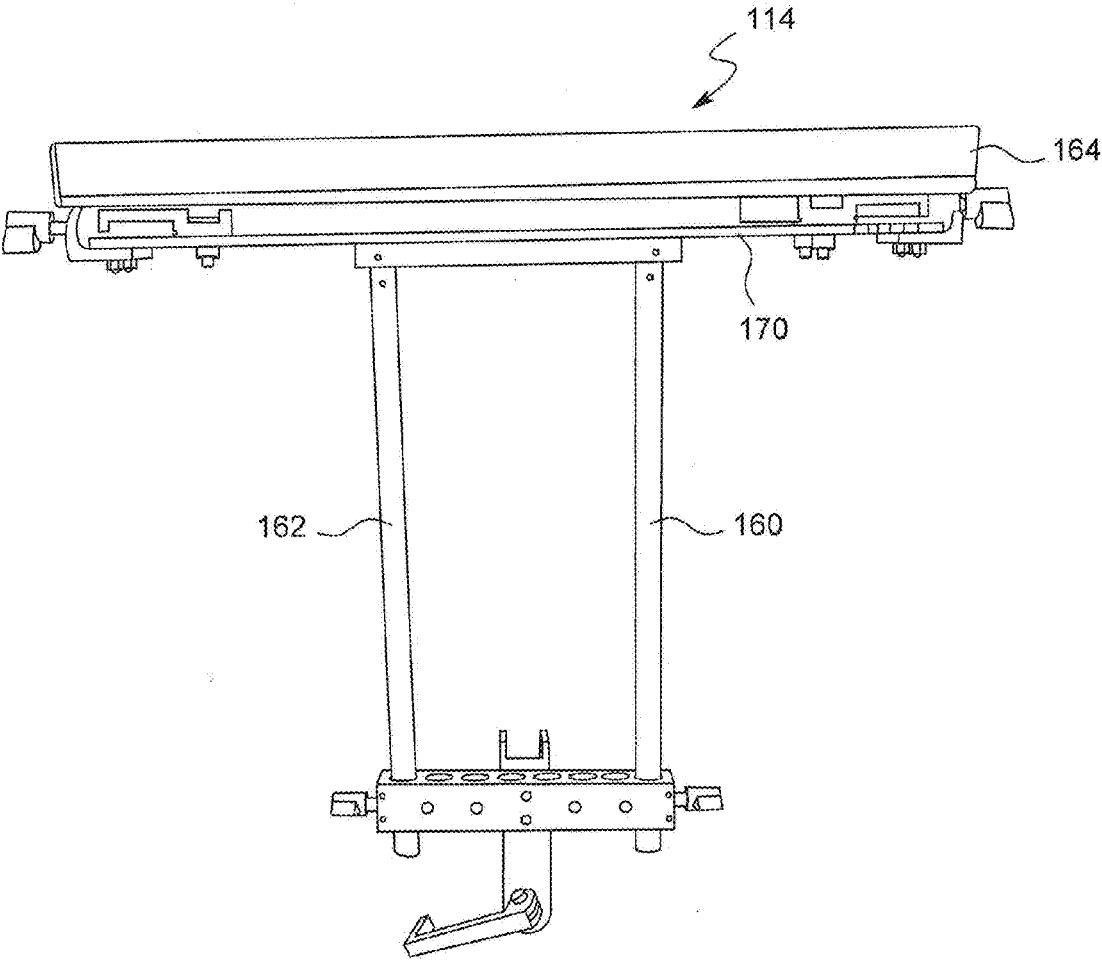

FIG. 10

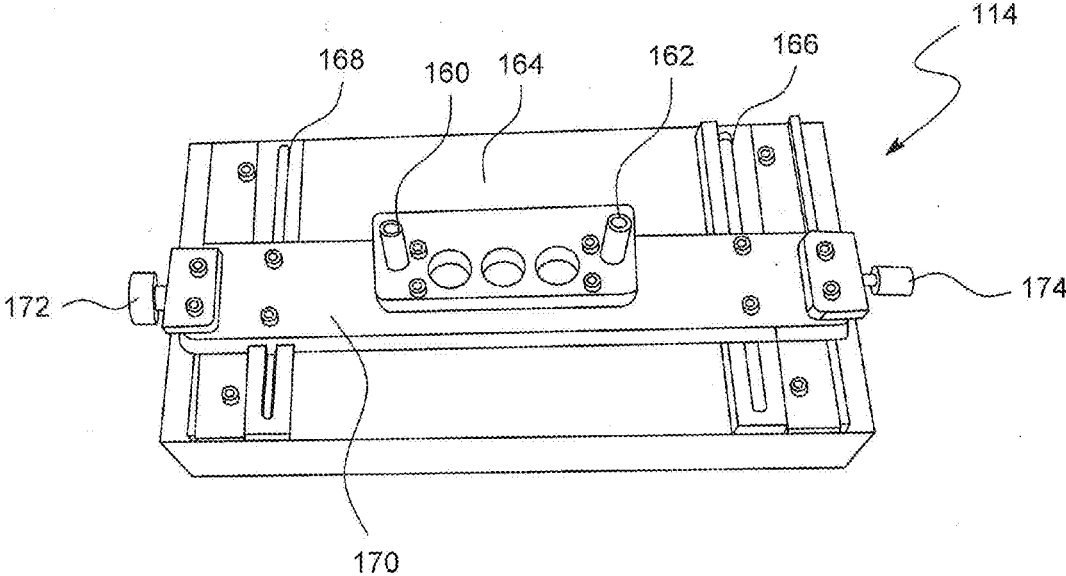

FIG. 11

MULTI-PURPOSE LITTER CLAMP AND ATTACHMENTS

CLAIM OF PRIORITY

[0001] This application claims the benefit of U.S. Provisional Application No. 62/410,467 filed Oct. 20, 2016, which is incorporated herein by reference in its entirety.

FIELD OF THE INVENTION

[0002] The present invention relates to clamps and attachments thereto for use with litters (a.k.a. stretchers) for use in providing medical assistance to wounded soldiers.

BACKGROUND OF THE INVENTION

[0003] Badly wounded soldiers, marines, sailors, airmen, and noncombatant civilians are typically carried on a stretcher or "litter" in U.S. military parlance from the point of injury to a place of medical treatment such as a Battalion Aid Station or other field hospital, and then subsequently to a rear-area fully-equipped Base hospital.

[0004] While being treated in a field hospital, the patient usually lies on a litter supported on litter stands, which are essentially folding tubular metal sawhorses.

[0005] When the patient has been stabilized, he is typically transferred to a major combat theatre hospital such as Bagram Air Base in Afghanistan, and subsequently either to a major regional military hospital such as Ramstein Air Base in Germany, and/or directly to a military hospital in America such as the Brooke Army Burn Center in San Antonio, Tex.

[0006] Generally depending on the nature and the severity of injury, throughout the above process, the patient lying on the litter is commonly connected to a variety of life-sustaining medical support equipment such as a) one or more gravity-fed intravenous (IV) fluid bags suspended from a hook on an IV pole above the litter; b) an oxygen bottle and valve/regulator; c) a fluid management device that heats refrigerated blood or plasma before infusing it into the patient; d) a ventilator; e) a vital signs monitor; and f) other medical field trauma-care items.

[0007] The current problems here are, when the litter bearing the patient moved from one point to another, how to move medical equipment connected to the patient. And further how and where to secure this medical equipment connected to the patient while the patient is on a litter in a field hospital without setting it on the floor if, as often the case, there are no tables or portable stands available to support medical equipment beside the litter.

[0008] Out of necessity during transport, connected pieces of medical equipment are often placed on the patient's chest or on the litter between the patient's legs. The medical items connected to the patient can be transported on a cart if available, or can be carried by accompanying medical personnel, but in both cases, there is risk of the equipment being accidentally dislodged.

[0009] Regarding IV bags and IV poles, most U.S. military litters have integral mounting holes to support IV poles. However, there are many litters including the so-called "NATO litter" in common use that do not have IV pole mounting holes.

[0010] Currently, the only mounting system for securely attaching medical equipment to a litter to my knowledge is the Special Medical Emergency Evacuation Device or "SMEED". This was invented and patented by Staff Ser-

geant Eric Smeed of the U.S. Army in 2000 as U.S. Pat. No. 6,493,890. It consists of a 14"×22" platform with multiple attachment points, and is designed to be fixed to the litter above the patient's lower legs.

[0011] The SMEED's shortcomings are a) it is fairly space-consuming, bulky, and heavy; and b) it being fixed on the litter above a patient's lower extremities restricts access to the patient's lower extremities; and c), it being fixed on the litter above the patient prevents the patient from being readily taken off the litter without removing it and possibly in the process accidentally dislodging medical equipment connected to the patient.

[0012] Thus, there is the need exists for a rapid and effective method of securely attaching and subsequently removing medical equipment connected to a patient directly to the litter on which the patient lies, such that the equipment accompanies the patient and litter both during transport and while in a field hospital.

SUMMARY OF THE INVENTION

[0013] It is an object of many embodiments of the present invention to provide a litter clamp having jaws which connect to opposing poles of a litter with a crossbar spanning below a bed of the litter.

[0014] It is another object of many embodiments of the present invention to provide a litter clamp which secures to both poles of a litter and provides a plurality of attachment locations for receiving medical equipment and/or accessories to assist in treating a patient on the litter.

[0015] It is an object of many embodiments of the present invention to provide a clamp which provides a mount which can possibly receive a bottle holder, possibly in either or both of a horizontal and vertical position.

[0016] It is an object of many embodiments of the present invention to provide a clamp which provides a mount which receives an IV pole.

[0017] It is an object of many embodiments of the present invention to provide a clamp which provides a mount which receives a tray, the tray preferably being at least one of elevationally adjustable and having a pan or platform mounted to a base whereby the pan/platform structure can slide in our out relative to the base thereby positioning the pan/platform either over a portion of the patient and/or at least partially external to the area above the litter.

[0018] While various embodiments can connect to litter poles in different manners, all embodiments have first and second jaws which are received at least partially about the litter poles, respectively. A crossbar connects the jaws and spans a distance below the jaws and the bed of the litter. For many embodiments, outwardly disposed relative to the clamp and jaws are mounts which have at least one, if not a plurality of spaced apart, or even symmetrically disposed attachment locations. A rail can be located outwardly relative to the mount. The attachment locations can be vertically aligned bores which receive a shaft, shank, rod or other structure there through, which for many embodiments can be selectively secured in place with an operator (such as to set at a specific elevation, prevent from rotation, etc.).

[0019] Various attachments can attach at the locations including, but not limited to an iv pole, a tray and a bottle holder. These attachment can also potentially provide unique features whether it be a bottle holder that can quickly and/or easily be manipulated to accept bottles/tanks of different height and/or width (i.e., diameter for many bottles), a tray

that may be elevationally adjustable and potentially provide a base with at least one of a pan or platform that can be slid relative to the base so that the pan/platform can be moved to be positioned (and then locked) so that it is either more over a patient's body and/or principally externally disposed relative to a patient when on the litter.

[0020] Still other embodiments may have these and/or other features.

BRIEF DESCRIPTION OF THE DRAWINGS

[0021] The present invention, in accordance with one or more various embodiments, is described in detail with reference to the following figures. The drawings are provided for purposes of illustration only and merely depict typical or example embodiments of the invention. These drawings are provided to facilitate the reader's understanding of the invention and shall not be considered limiting of the breadth, scope, or applicability of the invention. It should be noted that for clarity and ease of illustration these drawings are not necessarily made to scale.

[0022] Some of the figures included herein illustrate various embodiments of the invention from different viewing angles. Although the accompanying descriptive text may refer to such views as "top," "bottom" or "side" views, such references are merely descriptive and do not imply or require that the invention be implemented or used in a particular spatial orientation unless explicitly stated otherwise.

[0023] FIG. 1 is a perspective top view of a multi-purpose litter clamp attached to a litter showing accessories assembled to the litter of a presently preferred embodiment of the invention;

[0024] FIG. 2 is a perspective top view of a multi-purpose litter clamp of a first alternative embodiment, but similar to FIG. 1, unattached from the litter shown in FIG. 1;

[0025] FIG. 3 is a front perspective view of the multi-purpose litter clamp of FIG. 1 in a disassembled configuration;

[0026] FIG. 4 a top view of the multi-purpose litter clamp of FIGS. 1-3;

[0027] FIG. 5 is a bottom close-up view of a left side of a multi-purpose litter clamp of a second alternatively preferred embodiment showing a cam-action lever handle and a threaded rod without a surgical side rail attached;

[0028] FIG. 6 is a cross sectional view taken along the line A-A of FIG. 2;

[0029] FIG. 7 is a side perspective view of an oxygen bottle holder holding an oxygen bottle removed from the litter shown in FIG. 1;

[0030] FIG. 8 is a perspective view of the oxygen bottle holder of FIG. 7;

[0031] FIG. 9 is a side plan view of the oxygen bottle holder of FIGS. 1, 7 and 8 connected in a different configuration to the litter of FIG. 1;

[0032] FIG. 10 is a side plan view of the multi-purpose litter clamp attached to the litter showing a tray accessory assembled to the litter as is shown in FIG. 1 in an elevated configuration; and

[0033] FIG. 11 is a bottom perspective view of the tray of FIGS. 1 and 10.

[0034] The figures are not intended to be exhaustive or to limit the invention to the precise form disclosed. It should be understood that the invention can be practiced with modi-

fication and alteration, and that the invention be limited only by the claims and the equivalents thereof.

DETAILED DESCRIPTION OF THE EMBODIMENTS OF THE INVENTION

[0035] From time-to-time, the present invention is described herein in terms of example environments. Description in terms of these environments is provided to allow the various features and embodiments of the invention to be portrayed in the context of an exemplary application. After reading this description, it will become apparent to one of ordinary skill in the art how the invention can be implemented in different and alternative environments.

[0036] Unless defined otherwise, all technical and scientific terms used herein have the same meaning as is commonly understood by one of ordinary skill in the art to which this invention belongs. All patents, applications, published applications and other publications referred to herein are incorporated by reference in their entirety. If a definition set forth in this section is contrary to or otherwise inconsistent with a definition set forth in applications, published applications and other publications that are herein incorporated by reference, the definition set forth in this document prevails over the definition that is incorporated herein by reference.

[0037] The present invention is directed toward a multi-purpose litter clamp 10, also referred to as a Doak multi-purpose litter clamp, which preferably comprises a clamp 10 that can span across and below a litter 12 to connect onto the opposing longitudinal litter poles 14,16 on opposite sides of the litter 12. There are a number of ways the clamp 10 can connect to the poles 14,16 as will be explained below for various embodiments.

[0038] By attaching rigidly and securely to both sides of the litter 12, the clamp 10 can eliminate a problem of clamps that fit just one side of the litter 12 (which may tend to rotate out of position about a litter pole 14,16 and/or suffer other defects). In many embodiments, all but a few inches of the longitudinal poles 14,16 of the litter 12 are covered with a nylon or other fabric 18 that makes up the bed 20 of the litter 12. The fabric 18 is normally stretched tightly between the poles 14,16 in an in-use configuration through the use of struts 22,24 and 26,28 which are normally pivotably connected (so that they can transition between a storage position (not shown) and an in-use configuration illustrated). At ends of the struts 22,24,26,28 below the poles 14,16 are often feet (not shown) which can support the litter 10 above the ground, typically a few inches.

[0039] In the absence of a fairly massive and heavy clamping device, prior art single-side litter clamps are prone to 'drooping' or rotating on the litter pole's nylon fabric covering from the weight of the medical equipment, and consequently not rigidly secured to the litter.

[0040] As shown in FIG. 1 illustrates an embodiment of the multi-purpose litter clamp 10 attached to the litter 12 with at least one of the illustrated accessories and/or others assembled to the litter 12 and clamp 10 in the form of a bag support or iv pole 110, a tank support or bottle holder 112 with tank 120 attached thereto, and a tray 114. FIG. 2 shows the clamp 10 having rails 38,40 (first and second) externally disposed relative to attachment locations 42,44,46,48 (also to mounts 90,92, jaws 52,54 and/or crossbar 50) which will be discussed in further detail below.

[0041] A $\frac{3}{4}$ " square $\frac{1}{8}$ " wall aluminum tube or other structure may function as a crossbar **50** bridging the two opposing litter longitudinal poles **14,16**. On each end of this crossbar **50** (and above) and at least substantially perpendicularly disposed thereto are vertical jaws **52,54** (first and second) operably coupled together with the crossbar **50**. Some jaws **52,54** may be approximately 1" wide by $\frac{3}{4}$ " high, possibly made of aluminum providing a half-moon shaped cutout with a radius cooperating with the longitudinal pole **14,16** and its fabric **18** (which is often covering over much of the poles **14,16**). The 'half-moon' cut-outs **51,53** can provide a similar radius (preferably slightly oversized) to cooperate with the diameter of the litter poles **14,16** (and fabric **18** thereabout). This is both to firmly grip the litter poles **14,16** and most important, secure the litter clamp **10** to the litter **12**. Jaws **52,54** may be inwardly oriented as shown relative to the crossbar **50** and/or outwardly oriented (not shown).

[0042] As shown in FIG. 3 and others, crossbar **50** may be made of more than one piece, such a two piece **56,58** embodiment shown in FIG. 3. Pieces **56,58** can connect intermediate the jaws **52,54** in an installed configuration with a resiliently biased ball **60** of first piece **56** received in a bore **62** of second piece **58** to provide for a rigid and secure connection when connected, while permitting rapid assembly/disassembly.

[0043] The embodiment of FIG. 3 has jaws **52,54** that have thumbs **64,66** respectively which are operably coupled to operators **68,70** respectively which move the thumbs **64,66** into the cutouts of the jaws **52,54** to connect securely to poles **14,16** (and fabric **18** therearound, if present at that location). In this embodiment, the thumbs **64,66** move vertically while the operators **68,70** rotate shafts **72,74** along horizontal axes. The embodiments of FIGS. 2 and FIG. 5 operate differently.

[0044] As shown in FIG. 3, the crossbar **50** can be approximately 2" below the contact joint of the jaws **52,54** that clamp on the litter poles **14,16** (jaws **52,54** are illustrated above the crossbar **50** in this embodiment). Many litter stands have a 'dropped' cross bars or struts as described above to provide clearance for the patient's body lying on the litter bed. Without that, the fabric **18** of the litter **12** would often stretch and sag under the weight of the patient's body and create pressure points where the patient's body makes contact through the litter fabric **18** with the crossbar or struts of the litter stand. The dropped crossbar in the litter clamp **10** can meet the same objective. Litter fabric **18** refers to the material making up the bed **20** which is normally a nylon, but could be other material(s) provided as a sheet for other embodiments.

[0045] For the embodiment shown in FIG. 5, the jaw on one end of the crossbar **200** can be permanently connected, such as riveted or otherwise connected to the crossbar **200**. The clamping jaw **202** on the other end of the crossbar **200** can be connected to a sleeve **204** that telescopes over (or into) the cross bar **200**. This sleeve **204** with the jaw **202** slides outwardly to fit the clamp **10** over the opposing-side litter poles **14,16**, and then slides in to contact both litter poles **14,16**.

[0046] Inside the sleeve **204** can be a $\frac{1}{4}$ -20 threaded rod **208** (or other structure) fixedly secured inside the crossbar **200**. The other end goes through, around and/or beyond the illustrated jaw **202**, and can be secured with a swiveling cam-action lever handle **206** or other operator to secure the

sleeve **204** in a locked configuration to possibly provide a biasing force of the jaws **202** (the other not shown) toward one another as would be understood by those of ordinary skill in the art. When the litter clamp **10** is fitted over the opposing-side litter poles **14,16** and the sleeve **204** pushed it to take up the slack, turning (or pivoting about pivot **210**) the swiveling cam-action lever handle **206** can rigidly compress the jaws **202** relative to each other, and in turn rigidly clamps the jaws **202** (other not shown) to the litter **12**. The clamping force on the litter **12** can be so great that it can visibly compress the distance between the opposing-side litter poles **14,16**. In the illustrated embodiments, the jaws **52,54** securely connect to the litter poles **14,16** respectively when installed. Spring **99** shown in FIG. 6 may be useful so that the clamps may be spring loaded whether a handle **206** is utilized to providing the clamping action or force, or not. Other spring biasing mechanisms may be utilized to assist in pulling jaws **202** (and **52,54** for some other embodiments) toward one another to connect to litter poles **14,16**.

[0047] FIG. 6 shows an alternately preferred thumb **76** which moves vertically into the first jaw **52** to secure the litter pole **14** or **16** therein. The operator **78** moves threaded rod **80** relative to threads **82** to push the thumb into the cutout of the jaw **52**. One difference between FIG. 6 and FIG. 3 is that the thumbs **64,66** and **76** are moved by operators **68,70** vs. **78** oriented in perpendicular directions. The operator **78** moves about the same axis **84** that the thumb **76** moves. Operators like operator **70** rotates about axis **86** which is perpendicular or substantially perpendicular to axis **88** (the direction the thumb **66** moves to secure the jaw **52** to the pole **14** or **16**).

[0048] Meanwhile, FIG. 6, like FIG. 2 shows mounts **90,92** (first and second mounts **90,92**) supporting attachment locations **42,44,46,48** (first, second, third and fourth, respectively) which could be vertically (or otherwise oriented) aligned bores. Mounts **90,92** are connected securely to the jaws **52,54**, such as with connectors **94,96** passing through a portion of jaws **52** such as back **99** (opposite cut out **51** to thus be below a litter pole **14,16** when installed) and being securely retained in bores **98,100** of mounts **90,92** as would be understood by those of ordinary skill in the art or otherwise. Mounts **90,92** can connect to optional side rails **38,40** (which may be removable in some embodiments).

[0049] In many embodiments, the clamp **10** can within ten seconds or less be attached to the litter **12** and tightened, and provide a rigid and secure mount for various medical equipment to be attached to the litter **12**.

[0050] Operators such as operators **102,104,106,108** can be used to selectively securely connect to rods or other structures directed into and/or through attachment locations **42,44,46,48** as would be understood by those of ordinary skill in the art (such as by directing an internal threaded shaft against a rod, turning a cammed shaft against a rod, etc.)

[0051] Attachment locations **42,44,46,48** can receive a variety of attachments. FIG. 1 shows an IV pole **110**, a bottle holder **112** and a tray **114**. Other attachments could be connected in similar or dissimilar manners. Connecting an IV pole **110** having a $\frac{1}{2}$ inch diameter is straightforward for many embodiments. The pole **110** can be received within an attachment location **42,44,46,48** and secured with the appropriate operator **102,104,106,108**. With the IV pole **110** connected, any bags supported thereon can be supported by a securely connected pole **110** to the litter **12** so the patient could be moved with the litter **12** to various locations as

necessary. Attachment locations **42,44** and/or **46,48** may be symmetrically disposed relative to jaws **52,54** or not for various embodiments.

[0052] Operators **102,104,106,108** could be $\frac{1}{4}$ -20 threaded locking thermoplastic knobs with elastomer covers for comfort and nonslip grip. They can be secured with a $\frac{1}{16}$ " diameter stainless steel wire tether riveted to the tube to prevent the locking knob ever backing out and being lost. Turning the knob clockwise rigidly can secure the IV pole **110** or other pole-mounted device to the mount **90** and in turn the litter **12**.

[0053] Some mounts **90,92** as shown in at least FIGS. **1** and **5** could have $\frac{1}{4}$ " diameter holes (or other mounting system), such as one inch apart or the top and bottom surfaces in addition to and/or instead of attachment locations **42,44,46,48**. These are for ready attachment points for custom medical equipment brackets to mount whatever present and future medical devices the user employs.

[0054] On the outer surface of mounts **90,92** can be bolted or otherwise a $\frac{5}{16}$ " thick by $1\frac{1}{8}$ " high by 6" long aluminum operating table surgical equipment side rail **38** and/or **40**, identical to those on the Doak Portable Surgical Table. These rails **38,40** can provide mounting surfaces for any medical or surgical equipment the user has that mounts on a surgical table side rail. The rails **38,40** are preferably outwardly disposed relative to the jaws **52,54** and/or mounts **90,92**.

[0055] Many embodiments provide a quick-connect and quick-disconnect rigid litter mounting system, that within seconds can be adjusted in tension without tools, for almost any medical device the user employs for wounded patients both in transport and while in field hospitals.

[0056] Oxygen bottles or other tanks **120** are commonly put between a patient's legs on the litter when being transported, and often set on the floor when the patient is on a litter and litter stand in a field hospital.

[0057] FIGS. **7-9** showing side views of opposite sides of a bottle holder **112** holding a tank **120** such as an oxygen bottle. The bottle holder **112** can be made from $\frac{1}{8}$ " and $\frac{1}{4}$ " thick aluminum (or other material) that may be contoured to securely hold oxygen bottles commonly used by the U.S. military in field transport and in field hospitals. It secure oxygen bottles or other tanks **120** both with quick-acting adjusting threaded knobs **122,124** and high-strength straps **126,128** with quick-acting metal adjusters **130,132**.

[0058] The bottle holder **112** can in just a few seconds or less be mounted in or at one or more of the attachment locations **42,44,46,48** on the litter clamp **10**. Gravity alone could hold it in place, or it could also be secured with the threaded knob (operator **102,104,106** or **108**).

[0059] Since different military medical units use different sizes of oxygen bottle sizes for patient transport, the Bottle Holder **112** can be adjusted, preferably without tools, in a few seconds or less for both different lengths and diameters of commonly used U.S. military oxygen bottles. Specifically, the holder **112** has a back **133** comprised of first and second pieces **134,136** slidably connected together with at least one piece **134,136** having a slot **138** through which knob **122** can selectively position and secure one piece **134** relative to the other piece **136**. A similar or dissimilar construction can be provided for base pieces **138,140** (which also may have slots **144**) so that they may be moved in and out relative to foot **142** (which connects to back **133**) to

accommodate various diameter tanks **120**. Knob **124** can secure the base pieces at desired locations to accommodate a particular tank **120**.

[0060] Meanwhile first and/or second extensions **146,148** can extend from back **133**. The first extension **146** could be operably coupled to be directed parallel to the second extension **148** such as illustrated in FIG. **7** and to then be received within two attachment locations **42,44** or **46,48** as illustrated in FIG. **9** to orient the tank **120** horizontally as shown in that figure. First extension could also be positionable such as by rotating post **150** downwardly such as by loosening and then retightening nuts **152,154** so that post **150** extends parallel to (or substantially parallel to) back **133** so that the post can be put in any of the attachment locations **42,44,46,48** such as is shown in FIG. **1**. Such a connection optimizes the "real estate" along the poles **14,16** for access and/or other uses. Second extension, if utilized, may be operably coupled to back **133**, such as with a slide **156**.

[0061] The bottle holder can swivel 90 degrees, possibly without tools, in in a few seconds to hold an oxygen bottle or other tank **120** either perpendicular to the ground (vertically) or horizontally, whichever the field medical personnel wish.

[0062] Hanging an oxygen bottle vertically occupies the least space alongside the litter **12**, and as such minimizes the room taken up by a surgeon or medic working alongside the litter. Mounting the oxygen bottle horizontally facilitates stacking litters with patients in medical evacuation or "medevac" vehicles, where litters and patients on certain medevac aircraft can be stacked three high. Also, holding the oxygen bottle horizontally reduces how far the oxygen bottle and holder extends from the side of the litter, to minimize the combined litter/oxygen bottle side-to-side footprint.

[0063] Depending on the suitability of the requirement, it observed to find out how much less the oxygen bottle extends from the litter when mounted horizontally than when mounted vertically. The downside is, mounted horizontally, the oxygen bottle takes up much more 'real estate' along the side of the litter, and as such could be in the way of attending medical personnel.

[0064] In the field of military field trauma care, transport, and field hospital use, a tray where the medical instruments, medicines and the like to be places other than on the patient or on the ground can be helpful.

[0065] One of the Doak Litter Clamp accessories could include an 8" wide by 16" long lightweight aluminum tray (or other tray), possibly with welded corners and double-hemmed 1' high vertical walls for strength to provide a pan **164**. It could be designed to hold bandages, antiseptics and medicine, medical instruments, etc., and/or anything that might fit within its 8" by 16" perimeter walls. Other pans or platform configurations can be provided with other embodiments and certainly everything on it need not fit within its perimeter.

[0066] It has been tested that the exemplary tray **114** can hold 20 pounds without deformation. Other embodiments may behave differently. The tray **114** can mount instantly on the litter clamp **10** attachment locations **42,44,46,48** possibly with permanently-attached $\frac{1}{2}$ " diameter supporting stalks **160,162** that fit into the 13 mm holes utilized as attachment locations **42,44,46,48** in a preferred embodiment. These mounting stalks **160,162** can be secured with the operators **102,104,106,108**. Stalks **160,162** can be relative long such as shown in FIG. **10** or shorter as shown in

FIG. 11. Longer stalks **160,162** may be useful to elevate a platform or pan **164** above a patient. The use of two parallel stalks **160,162** can resist rotation and provide a more stable support than a single stalk alone for at least some embodiments.

[0067] Some embodiments provide possibly allow for the pan **164** to slide horizontally or otherwise over a portion of the patient such as by providing slots or slides **166,168** to permit sliding connection of a base **170** (having the stalks **160,162**) to the pan **164** so that the pan **164** can be selectively slid to a desired position relative to the base **170** and then secured in position with the operators **172,174**.

[0068] The pan **164** can be substantially over a portion of a patient on the bed **20** (substantially outwardly directed relative to the illustrated attachment locations **42,44,46,48** to which the pan **164** is connected), or moved to be less and less over the patient, even to the point of being over the attachment locations **42,44,46,48** (and outwardly directed relative thereto). Thus, the pan **164** is slidably and/or horizontally positionable to a selected position relative to the base **170** and the bed **20**.

[0069] The tray **112** can be provided with $\frac{1}{2}$ " diameter threaded aluminum extensions that can be threaded without tools into the fixed mounting stalks **160,162** on the underside of the tray. With these extensions, the tray can be height-adjusted to anywhere from 2" to 12" (or other elevation) above the litter. Other constructions may be utilized with other embodiments.

[0070] The pan **164** can slide on Teflon spacers to extend either outboard of the litter, or be positioned inboard over the litter if the attending medical personnel so desire.

[0071] The sliding tray **114** can be locked in any position inboard or outboard of the litter **12** with a pair of threaded thermoplastic knobs with elastomer covers for comfort and nonslip grip.

[0072] FIGS. **1** and **10** are illustrations showing tray **114** mounted on the multi-purpose litter clamp **10** in the outboard position with respect to the litter **12**. FIG. **1** shows the tray slid to be outwardly disposed over the rail **16** while FIG. **10** shows the tray possibly over the bed **20**.

[0073] Sliding the tray **114** inboard over the patient and litter **12** can minimize the outward extension of the tray **114** beyond the side of the litter **12**. This can be critical in reducing the side-to-side footprint of the litter **12** during medevac transport.

[0074] While various embodiments of the present invention have been described above, it should be understood that they have been presented by way of example only, and not of limitation. Likewise, the various diagrams may depict an example architectural or other configuration for the invention, which is done to aid in understanding the features and functionality that can be included in the invention. The invention is not restricted to the illustrated example architectures or configurations, but the desired features can be implemented using a variety of alternative architectures and configurations. Indeed, it will be apparent to one of skill in the art how alternative functional, logical or physical partitioning and configurations can be implemented to implement the desired features of the present invention. Also, a multitude of different constituent module names other than those depicted herein can be applied to the various partitions. Additionally, with regard to flow diagrams, operational descriptions and method claims, the order in which the steps are presented herein shall not mandate that various

embodiments be implemented to perform the recited functionality in the same order unless the context dictates otherwise.

[0075] Although the invention is described above in terms of various exemplary embodiments and implementations, it should be understood that the various features, aspects and functionality described in one or more of the individual embodiments are not limited in their applicability to the particular embodiment with which they are described, but instead can be applied, alone or in various combinations, to one or more of the other embodiments of the invention, whether or not such embodiments are described and whether or not such features are presented as being a part of a described embodiment. Thus, the breadth and scope of the present invention should not be limited by any of the above-described exemplary embodiments.

[0076] Terms and phrases used in this document, and variations thereof, unless otherwise expressly stated, should be construed as open ended as opposed to limiting. As examples of the foregoing: the term "including" should be read as meaning "including, without limitation" or the like; the term "example" is used to provide exemplary instances of the item in discussion, not an exhaustive or limiting list thereof; the terms "a" or "an" should be read as meaning "at least one," "one or more" or the like; and adjectives such as "conventional," "traditional," "normal," "standard," "known" and terms of similar meaning should not be construed as limiting the item described to a given time period or to an item available as of a given time, but instead should be read to encompass conventional, traditional, normal, or standard technologies that may be available or known now or at any time in the future. Likewise, where this document refers to technologies that would be apparent or known to one of ordinary skill in the art, such technologies encompass those apparent or known to the skilled artisan now or at any time in the future.

[0077] A group of items linked with the conjunction "and" should not be read as requiring that each and every one of those items be present in the grouping, but rather should be read as "and/or" unless expressly stated otherwise. Similarly, a group of items linked with the conjunction "or" should not be read as requiring mutual exclusivity among that group, but rather should also be read as "and/or" unless expressly stated otherwise. Furthermore, although items, elements or components of the invention may be described or claimed in the singular, the plural is contemplated to be within the scope thereof unless limitation to the singular is explicitly stated.

[0078] The presence of broadening words and phrases such as "one or more," "at least," "but not limited to" or other like phrases in some instances shall not be read to mean that the narrower case is intended or required in instances where such broadening phrases may be absent. The use of the term "module" does not imply that the components or functionality described or claimed as part of the module are all configured in a common package. Indeed, any or all of the various components of a module, whether control logic or other components, can be combined in a single package or separately maintained and can further be distributed across multiple locations.

[0079] Additionally, the various embodiments set forth herein are described in terms of exemplary block diagrams, flow charts and other illustrations. As will become apparent to one of ordinary skill in the art after reading this document,

the illustrated embodiments and their various alternatives can be implemented without confinement to the illustrated examples. For example, block diagrams and their accompanying description should not be construed as mandating a particular architecture or configuration.

What is claimed is:

1. A litter clamp for connecting to a litter having parallel first and second poles connected by a fabric, said clamp comprising:

first and second jaws operably coupled together by a crossbar, said jaws located above the crossbar with the jaws securely connected to both the first and second poles respectively; and

a first mount connected to the first jaw providing a first attachment location for connecting an attachment selected from a tray, an iv pole and a bottle holder to the litter.

2. The litter clamp of claim **1** further comprising a first rail connected to the mount, said first rail outwardly disposed from the mount and the first jaw relative to the crossbar.

3. The litter clamp of claim **1** wherein the first mount has a second attachment location symmetrically disposed relative to and spaced apart from the first attachment location.

4. The litter clamp of claim **1** further comprising a second mount connected to the second jaw providing a first attachment location for connecting an attachment selected from the group of a tray, an iv pole and a bottle holder to the litter.

5. The litter clamp of claim **1** wherein the first attachment location is a vertically aligned bore.

6. The litter clamp of claim **5** further comprising a first operator which cooperates with the first attachment location to selectively secure a shaft of an attachment therein.

7. The litter clamp of claim **1** wherein the first mount has first and second attachment locations, and the attachment is the tray, said tray having first and second parallel stalks received in the attachment locations whereby the tray is selectively elevationally adjustable relative to the attachment locations.

8. The litter clamp of claim **1** wherein the attachment is the tray, said tray having a base operably coupled to a pan, wherein said pan is slidably horizontally positionable relative to the base.

9. The litter clamp of claim **1** wherein the attachment is the bottle holder, said bottle holder having an extension cooperating with the attachment location, said extension selectively positionable in a horizontal and a vertical configuration.

10. The litter clamp of claim **1** wherein the attachment is the bottle holder, said bottle holder having a back comprised of first and second pieces which are slidably disposed relative to one another to be selectively set at a desired height for receiving a tank.

11. The litter clamp of claim **1** wherein the attachment is the bottle holder, said bottle holder having a base comprised

of first and second base sections which are slidably disposed relative to a foot another to be selectively set at a desired width for receiving a tank.

12. The litter clamp of claim **1** wherein the crossbar has first and second pieces selectively connected together intermediate the first and second jaws in the installed configuration.

13. A litter clamp for connecting to a litter having parallel first and second poles connected by a fabric, said clamp comprising:

first and second jaws operably coupled together by a crossbar, said jaws located above the crossbar with the jaws securely connected to both the first and second poles respectively; and

a first mount connected to the first jaw opposite the first jaw relative to the crossbar, said first mount having first and second attachment locations.

14. The litter clamp of claim **13** further comprising a second mount connected opposite the second jaw relative to the crossbar, said second mount having third and fourth attachment locations.

15. The litter clamp of claim **13** wherein the first mount is connected to the first jaw providing a first attachment location for connecting an attachment selected from a tray, an iv pole and a bottle holder to the litter.

16. The litter claim of claim **12** wherein the crossbar has first and second pieces selectively connected together intermediate the first and second jaws in the installed configuration.

17. A litter clamp for connecting to a litter having parallel first and second poles connected by a fabric, said clamp comprising:

first and second jaws operably coupled together by a crossbar, said jaws located above the crossbar with the jaws securely connected to both the first and second poles respectively; and

the crossbar comprised of first and second pieces selectively connectable at a connection intermediate the first and second jaws in an installed configuration.

18. The litter claim of claim **17** wherein the first mount is connected to the first jaw providing a first attachment location for connecting an attachment selected from a tray, an iv pole and a bottle holder to the litter.

19. The litter claim of claim **17** further comprising a first mount connected to the first jaw opposite the first jaw relative to the crossbar, said first mount having first and second spaced apart attachment locations.

20. The litter claim of claim **19** further comprising a second mount connected to the second jaw opposite the second jaw relative to the crossbar, said second mount having third and fourth spaced apart attachment locations.

* * * * *